

Typical Applications

- Supermarkets
- Commercial kitchens
- Food and beverage processing
- Hospitals
- Abattoirs
- Pharmaceutical plants
- Laboratories

Stainless steel

interconnecting drainage channel system

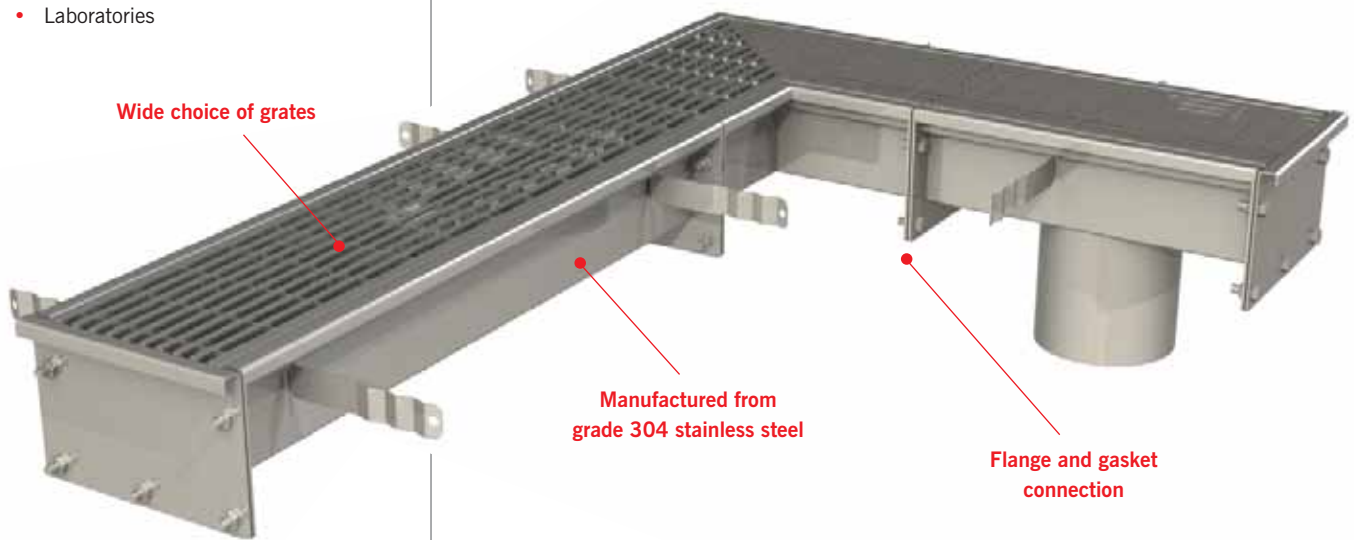

- Available to order off-the-shelf
- Manufactured from grade 304 stainless steel
- Modular format for ease of transportation and installation
- Flange and gasket connections for a secure seal
- Fixed and removable strainer option available
- Standard 100mm internal width to suit 5 grate styles, including Stainless 5 Star **Heelsafe® Anti-Slip**
- Wide range of grates available up to Load Class D (AS 3996)
- 3 edge profile options to suit various floor surfaces
- WaterMark approved: certificate number 23120
- Watertight tested to EN 1433



5 Star **Heelsafe® Anti-Slip**

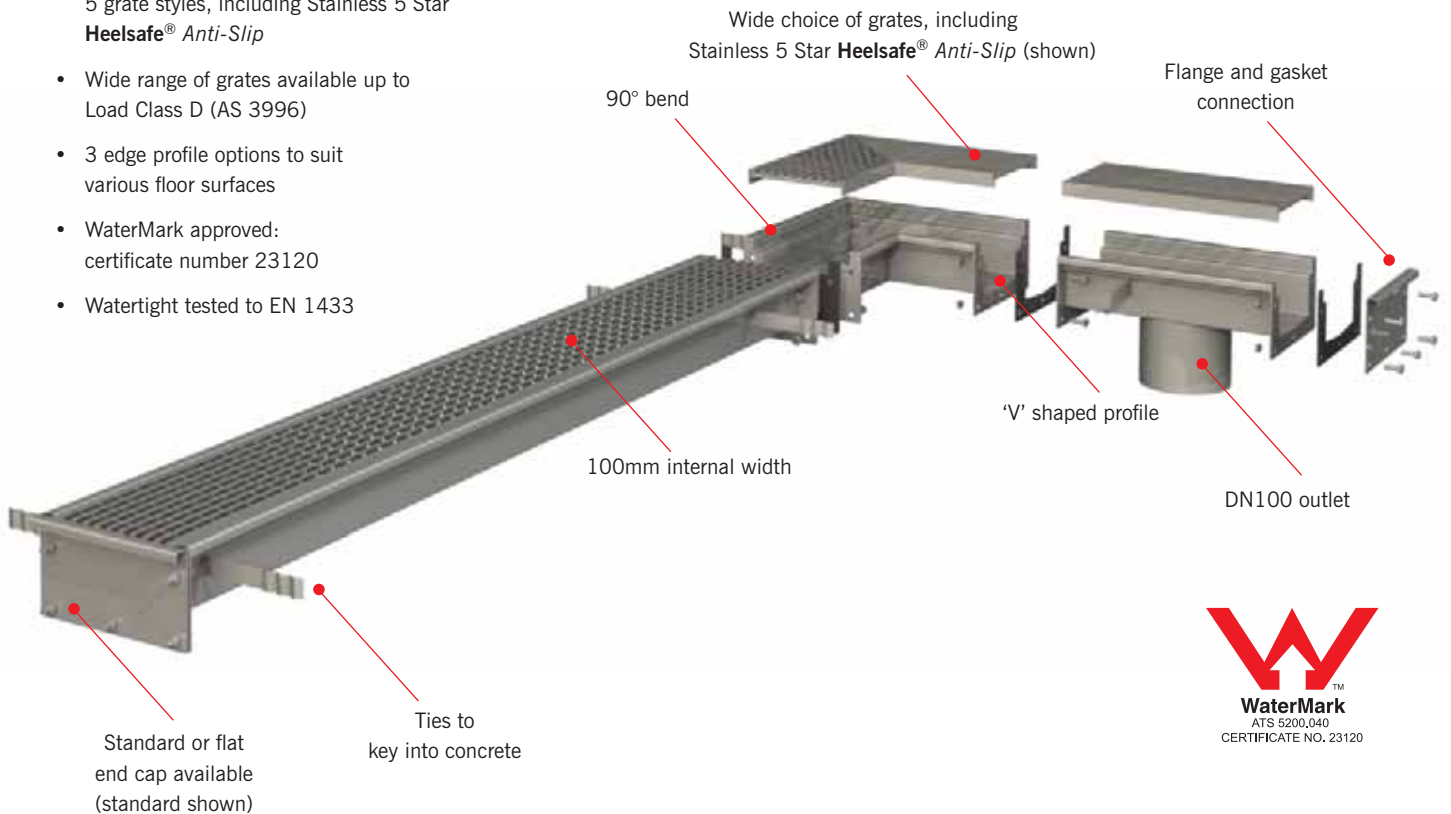

Edge Profile Options

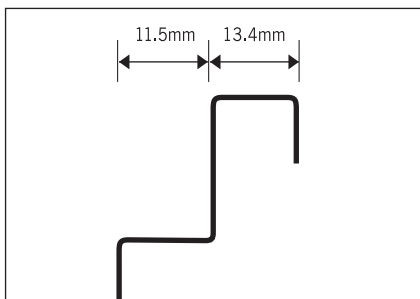

Standard Edge

An all purpose channel suitable for tiles, concrete and resin floors in pedestrian and light commercial applications.

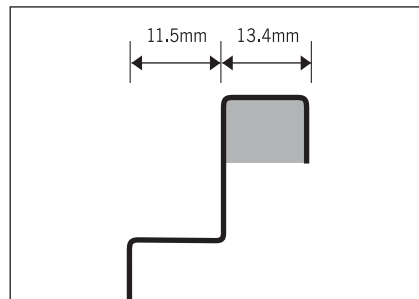

Solid Edge

Provides strength in dense traffic areas, and when floor surround is poured, avoids having to fill beneath the edge.

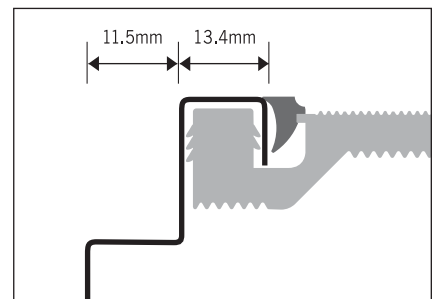

Vinyl Seal

Provides superior seal between channel and vinyl sheet flooring applications. Also suitable for some resin floor applications.

Modular 100 channels with outlet ¹



Part No.	Description	Weight kg
141477	250mm channel / DN100 outlet	1.3
141550	250mm channel / DN100 outlet / fixed and removable strainer	1.3
141478	500mm channel / DN100 outlet	2.1
141551	500mm channel / DN100 outlet / fixed and removable strainer	2.1
141554	1000mm channel / DN100 outlet	3.6
141552	1000mm channel / DN100 outlet / fixed and removable strainer	3.6
141485	250x250mm 90° bend / DN100 outlet	1.5
141553	250x250mm 90° bend / DN100 outlet / fixed and removable strainer	1.5

1. Each channel requires a bolt pack (part no. 141494), which provides a neoprene gasket and bolts to join the channels together. Ensure with every channel unit or end cap, a bolt pack is ordered.

Modular 100 channels ¹



Part No.	Description	Weight kg
141479	250mm channel	1.1
141480	500mm channel	1.7
141481	1000mm channel	3.2
141482	2000mm channel	6.5
141483	3000mm channel	9.5
141484	250x250mm 90° bend	1.3

1. Each channel requires a bolt pack (part no. 141494), which provides a neoprene gasket and bolts to join the channels together. Ensure with every channel unit or end cap, a bolt pack is ordered.

Modular 100 Accessories



Part No.	Description	Weight kg
141509	Standard end cap	0.2
141510	Flat end cap	0.2
141494	Bolt pack with neoprene gasket	0.6
90903	Solid edge strip - 1000mm length	1.0
141511	Vinyl seal - 1000mm length	0.5
141495	DN100 debris strainer	0.3
141581	DN100-DN80 coupling	0.3

Legislative requirements for grates:



AS 1428.2

Design for access and mobility - Part 2, clause 9(c) states:

If gratings are located in a walking surface, they shall have spaces not more than 13mm wide and not more than 150mm long. If gratings have elongated openings, they shall be placed so that the long dimension is transverse to the dominant direction of travel.



ACO offers a range of pedestrian grade gratings that have openings of less or equal to 8mm to prevent small heels becoming trapped, causing injury or falls.



Bicycle safe gratings should not trap or 'tram-line' bicycle wheels. Clause 3.3.6 of AS 3996 specifies the maximum slot length dependent on the width of slot for gratings that are deemed to be 'Bicycle tyre penetration resistant'.



These are gratings with slip resistant features. A slip resistance classification can be assigned to gratings. AS 4586 sets out two recognised tests that determine slip resistance: oil wet ramp (R-Rating) and wet pendulum. HB 197 references AS 4586 by specifying the minimum slip resistance ratings dependent on the application.



5 Star Heelsafe® Anti-Slip

Heelsafe® Anti-Slip Stainless Grates ¹

Part No.	Description	Weight kg	
141708	Stainless 5 Star Heelsafe® Anti-Slip Class B - 250mm	0.8	
141709	Stainless 5 Star Heelsafe® Anti-Slip Class B - 500mm	1.6	
141710	Stainless 5 Star Heelsafe® Anti-Slip Class B - 1000mm	3.2	
141711	Stainless 5 Star Heelsafe® Anti-Slip Class B - 90° bend	1.2	
141712	Stainless 5 Star Heelsafe® Anti-Slip Class C - 250mm	1.3	
141713	Stainless 5 Star Heelsafe® Anti-Slip Class C - 500mm	2.3	
141714	Stainless 5 Star Heelsafe® Anti-Slip Class C - 1000mm	4.5	
141715	Stainless 5 Star Heelsafe® Anti-Slip Class C - 90° bend	1.7	

¹ 5 Star grate meets R11 (oil wet ramp) and V (wet pendulum) AS 4586.

Other Grates

Part No.	Description	Weight kg	
141499	Stainless Slotted Class A - 500mm	1.0	
141500	Stainless Slotted Class A - 1000mm	2.0	
141718	Stainless Slotted Class D - 500mm	2.0	
141501	Stainless Slotted Class D - 1000mm	4.0	
141502	Composite Slotted Heelsafe® Anti-Slip Class D - 500mm	1.6	
141505	Stainless Mesh Class D - 500mm	1.8	
141506	Stainless Mesh Class D - 1000mm	3.5	
141507	Stainless Ladder Class D - 500mm	2.6	
141508	Stainless Ladder Slip Resistant Class D - 500mm	2.6	



Stainless Slotted Composite Slotted Heelsafe®

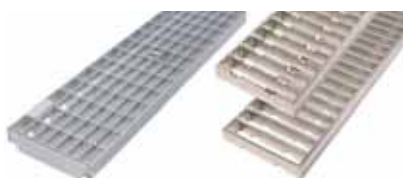

Stainless Mesh Stainless Ladder



ACO Polycrete Pty Ltd

ABN 65 050 102 942
www.acoaus.com.au

Sales Hotlines

Australia 1300 765 226
New Zealand 0800 448 080
International +61 2 4747 4000

Technical Support

email technical@acoaus.com.au

NSW

134-140 Old Bathurst Road
Emu Plains NSW 2750
acons@acoaus.com.au

QLD

467 Tufnell Road
Banyo QLD 4014
acoqld@acoaus.com.au

VIC / TAS

9 Overseas Drive
Noble Park VIC 3174
acovic@acoaus.com.au

WA

33-35 Sorbonne Crescent
Canning Vale WA 6155
acowa@acoaus.com.au

SA / NT

14/17-19 Churchill Road
Dry Creek SA 5094
acos@acoaus.com.au

NZ

Unit 2A, 49 Sainsbury Road
St Lukes, Auckland 1025
sales@acons.co.nz